

Prime line

MARK III SILENT TPS

Electric



CONTACT US

CERTIFICATION: CE UNI EN ISO 9001:2015



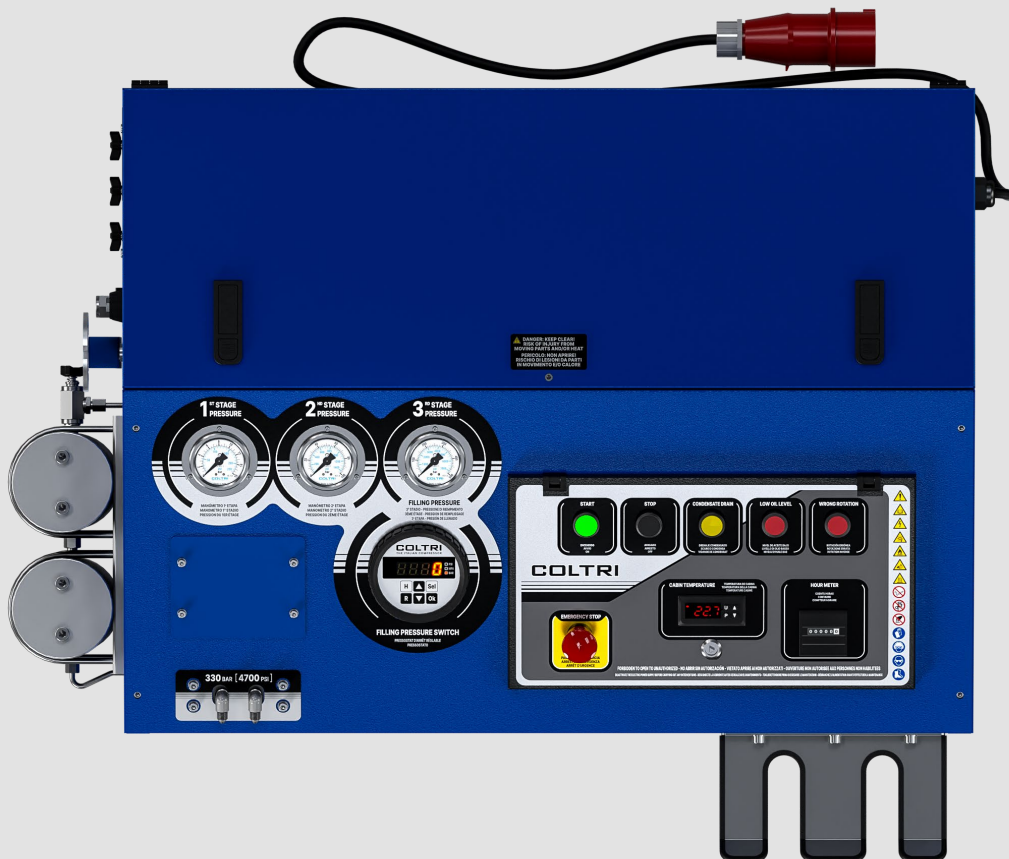

Technical data

Type of gas	Breathing air EN 12021 - Nitrox 40% max O2 - Helium - Nitrogen
Intake pressure	Atmospheric max 300 mbar
Nominal pressure	250 bar / 330 bar / 360 bar
Filling pressure	232 bar / 300 bar / 330 bar
Max working pressure	232 bar (single-phase electric) - 420 bar (three-phase electric)
Permissible ambient temperature range	-10° C ÷ +40° C
Permissible altitude	0 ÷ 1.500 m SLM
Max permissible tilt	15°
Design	Soundproof cabinet with sound absorbing
Operating voltage, standard	400 V; 50 Hz
Other operating voltage	230 V, 50 Hz / 440 V, 60 Hz / 230 V, 60 Hz
Oil	Synthetic Coltri Oil ST 755
Oil change interval	Every year / 1.000 h
Frame	Steel 1,5 mm thickness - colour RAL 5002 - Powder coating painting - scratch proof
Noise	LpA 72 dB

Compressor

	210 EM	235 ET	315 ET	345 ET	380 ET
Charging rate Measured during 10 liters cylinder filling from 0-200 bar tolerance +/- 5% at + 20 ° C ambient temperature.	210 l/min	235 l/min	315 l/min	345 l/min	380 l/min
Purification System	2 Hyperfilter				
Cooling air flow, min.	1.240 m ³ /h	1.960 m ³ /h	2.400 m ³ /h	1.960 m ³ /h	2.180 m ³ /h
Weight Standard model. Weight and dimensions may vary depending on accessories.	181 kg 299 lb	181 kg 299 lb	191 kg 421 lb	191 kg 421 lb	191 kg 421 lb
Dimensions (W x D x H)	112 x 73 x 91 cm - 44.1 x 28.7 x 38.8 in				

Motor

	210 EM	235 ET	315 ET	345 ET	380 ET
Power	4 kW, 5.5 Hp	4 kW, 5.5 Hp	5,5 kW, 7.5 Hp	7,5 kW, 10 Hp	
Type	Single-phase el.	Three-phase electric			
Operating voltage/frequency Different voltage / frequency available on request.	230 V, 50 Hz	400 V, 50 Hz			
Rated current	13,2 A				
Speed (RPM)	2.800	2.850	2.840	2.850	
Protection class	IP55 (TEFC)				

Dimensions

Width 112 cm (44.1")
 Depth 73 cm (28.7")
 Height 91 cm (38.8")

Dry weight

- MARK III SILENT TPS 210 EM**
181 kg (399 lb)
- MARK III SILENT TPS 235 ET**
181 kg (399 lb)
- MARK III SILENT TPS 315 ET**
191 kg (421 lb)
- MARK III SILENT TPS 345 ET**
191 kg (421 lb)
- MARK III SILENT TPS 380 ET**
191 kg (421 lb)

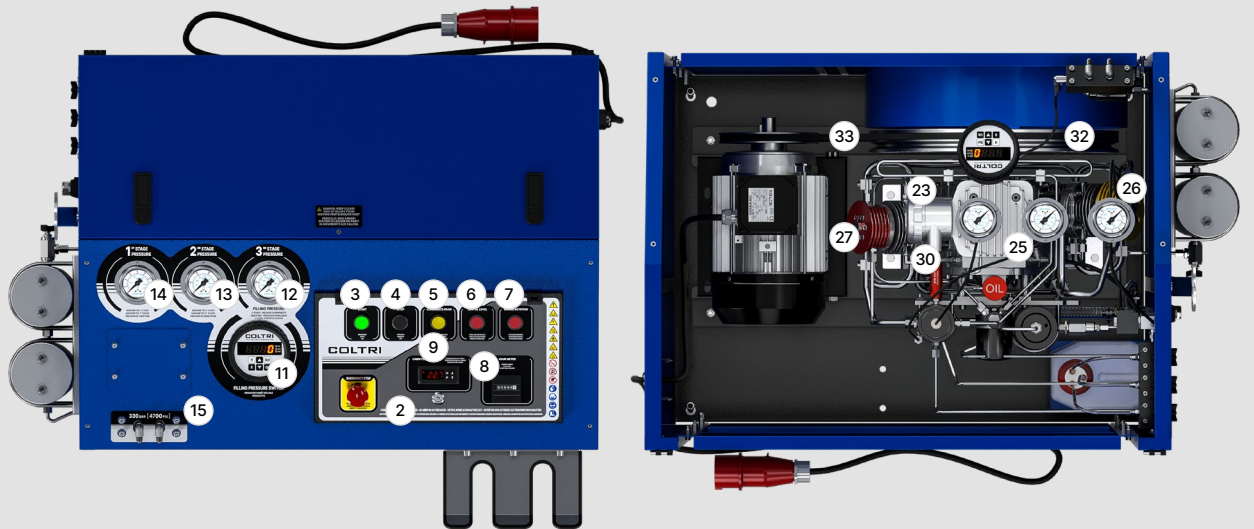
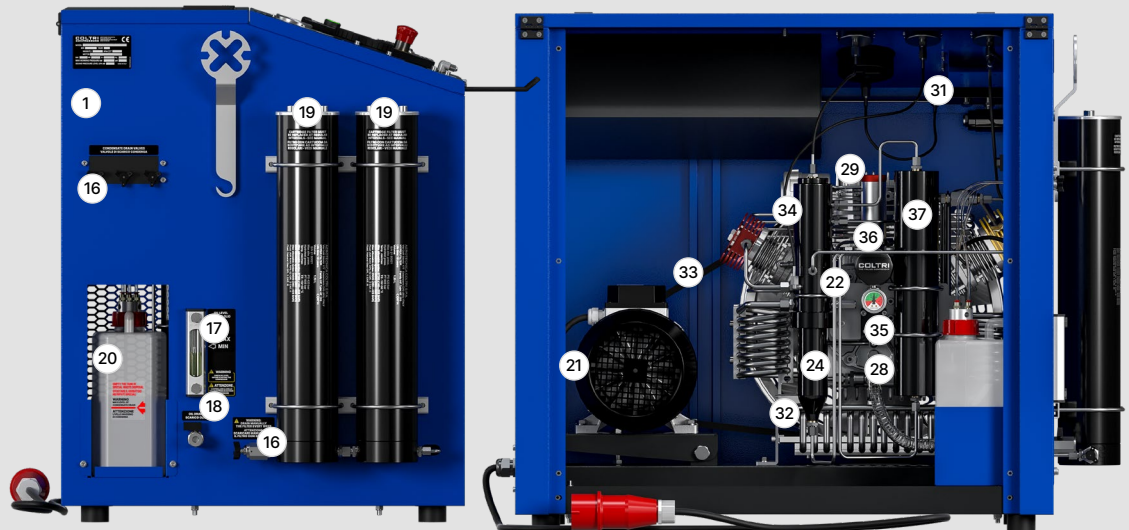

Machine parts

- | | | |
|--|--------------------------------|--|
| 1 Frame | 13 2nd stage pressure gauge | 26 2nd stage |
| 2 Control panel | 14 1st stage pressure gauge | 27 3rd stage |
| 3 ON pushbutton | 15 Refill hoses connection | 28 Monoblock crankcase |
| 4 Stop pushbutton | 16 Condensate discharge valves | 29 Oil filler plug |
| 5 Condensate discharge pushbutton | 17 Oil level | 30 Safety valve |
| 6 Oil level warning light | 18 Oil discharge valves | 31 Pressure maintenance valve |
| 7 Direction of rotation indicator light | 19 Purification system | 32 Cooling fan |
| 8 Hour counter | 20 Condensate collection can | 33 Belt |
| 9 Cabinet interior / cooling air temperature | 21 Electric motor | 34 HP condensate separator |
| 10 Emergency pushbutton | 22 Pumping unit | 35 Oil pump |
| 11 Automatic shut off pressure switch | 23 Intake air filter | 36 Oil filter |
| 12 3rd stage pressure gauge | 24 LP condensate separator | 37 HP High Efficiency condensate separator |
| | 25 1st stage | |

GP 315 TPS (ex MCH 16 TPS)

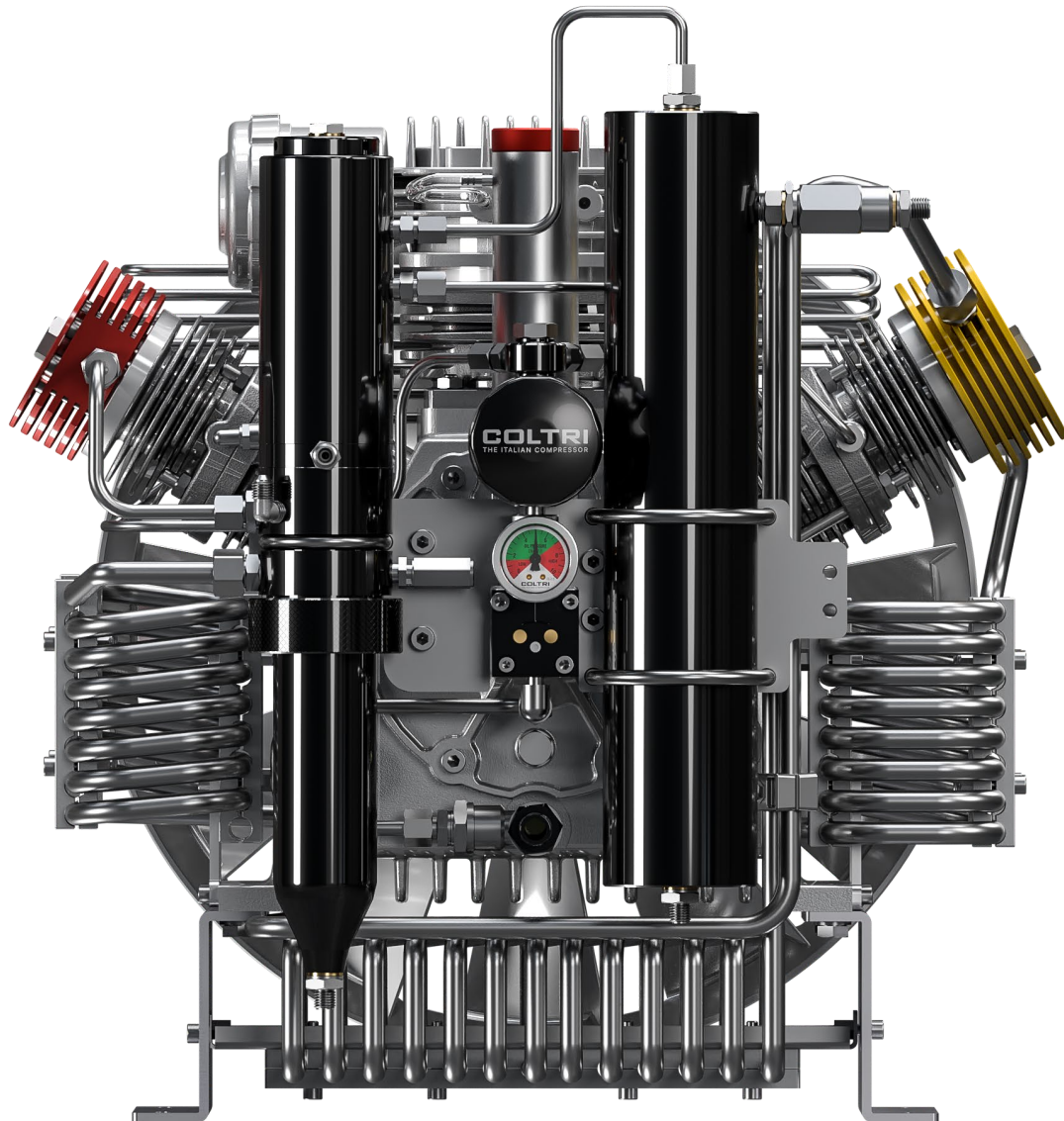

1. Forced lubrication with low pressure gear pump



2.
Suction filter:
10 μ micron

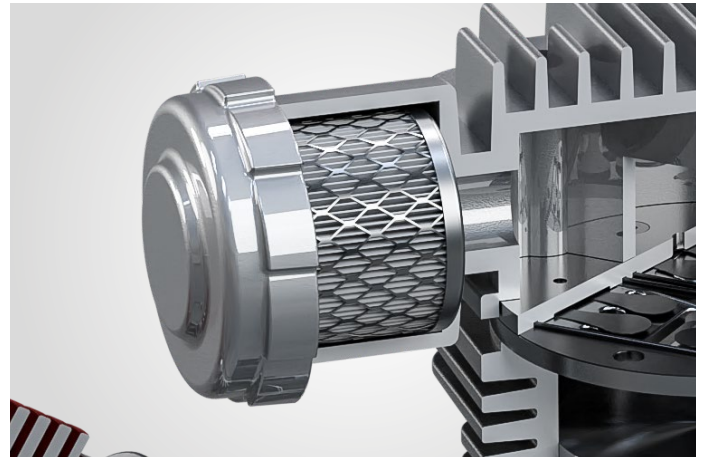

3.
Pipes, fittings and nuts
in stainless steel AISI 316



4.
Synthetic oil with
special formulation
for HP compressors



Discover more on Coltri Oil ST 755

5. Intermediate condensate separator after the second stage

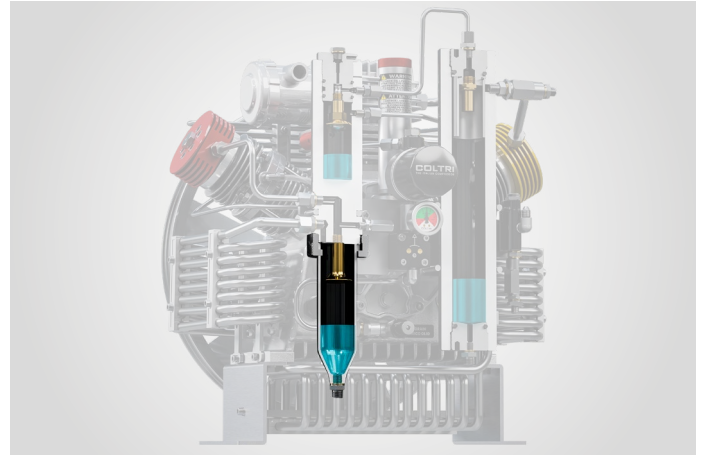

6. High pressure final condensate separator

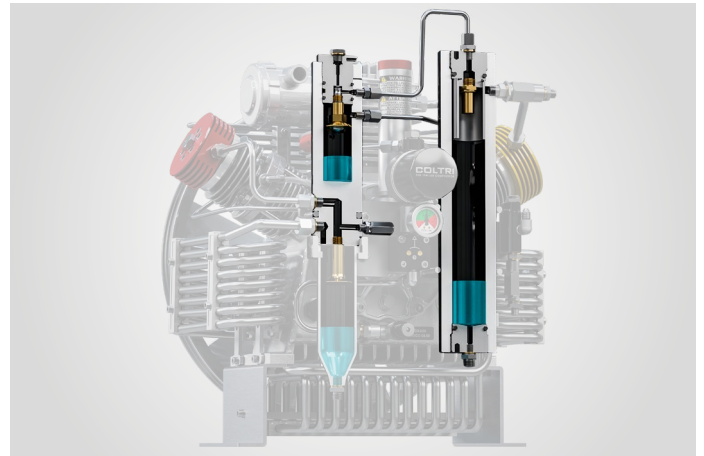

7. Safety valves after each stage of compression

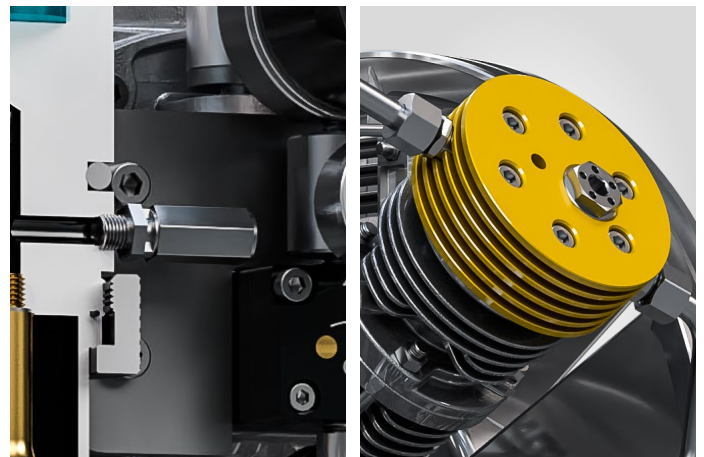

8. Die-cast aluminum cylinders with barrel coating in nicasil



9. Forged aluminum connecting rods



10. Forged steel crankshaft

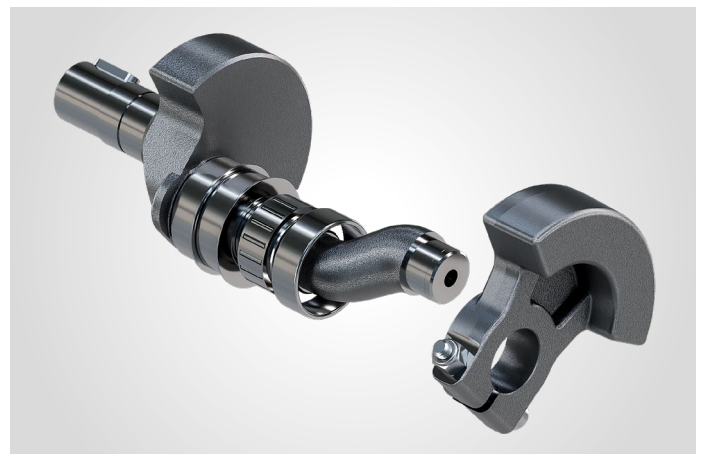

11. Stainless steel second and third stage valves

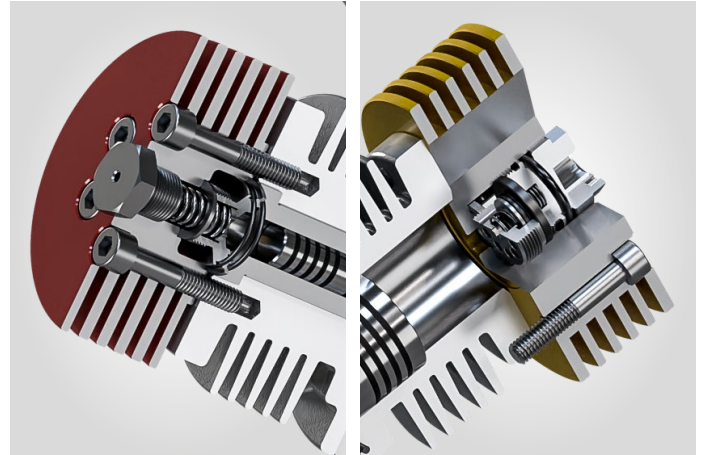

12. Roller Bearings for intensive work load



13. Third stage in tempered steel with 5 piston rings in special cast iron

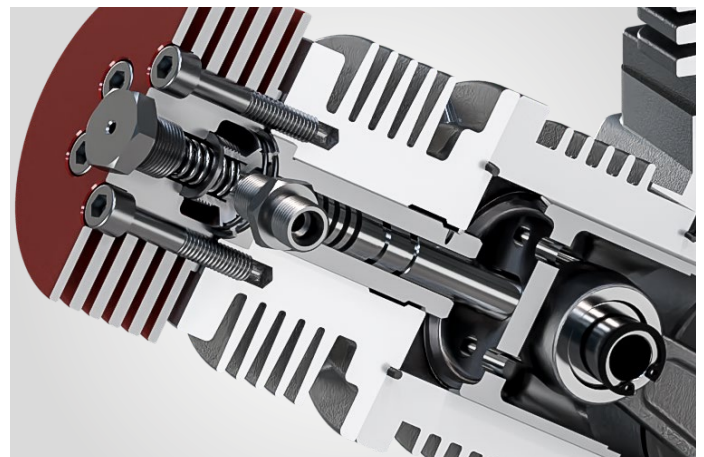

14.
 Second and third stage
 with pushing pistons
 to eliminate lateral forces
 on the pistons

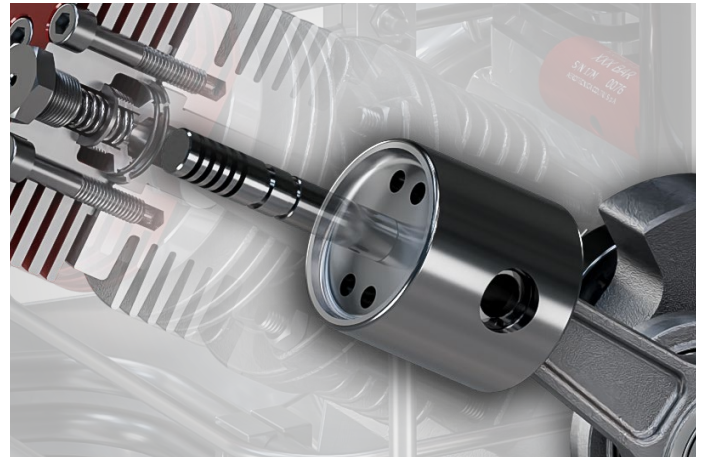

15.
 CE certification

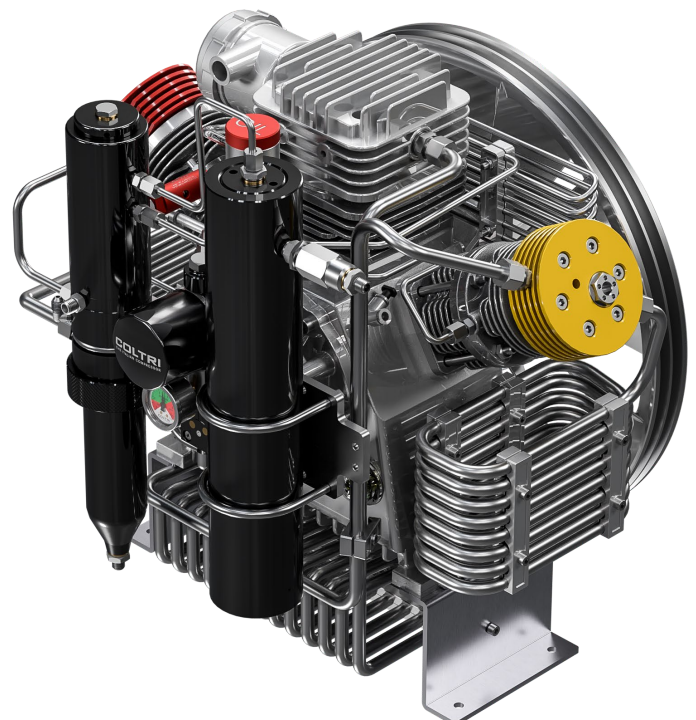
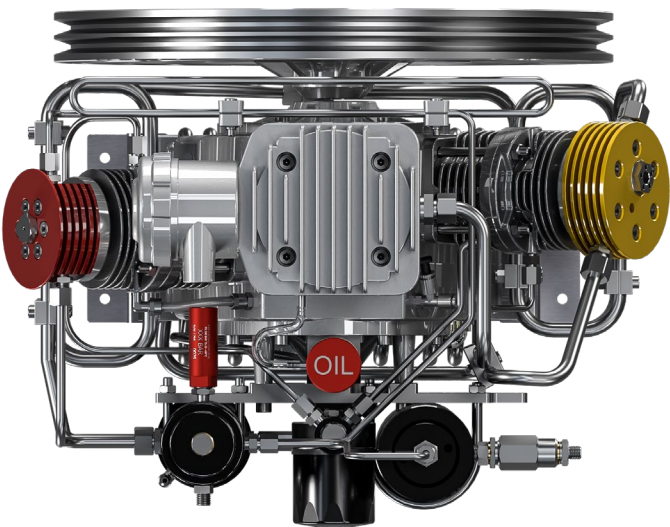
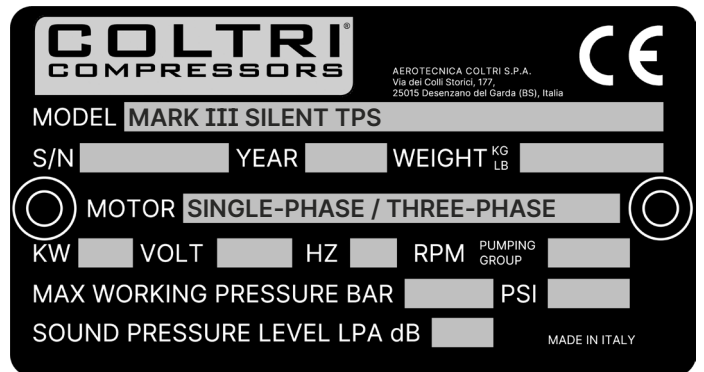

GP 380 TPS (ex MCH 23 TPS)

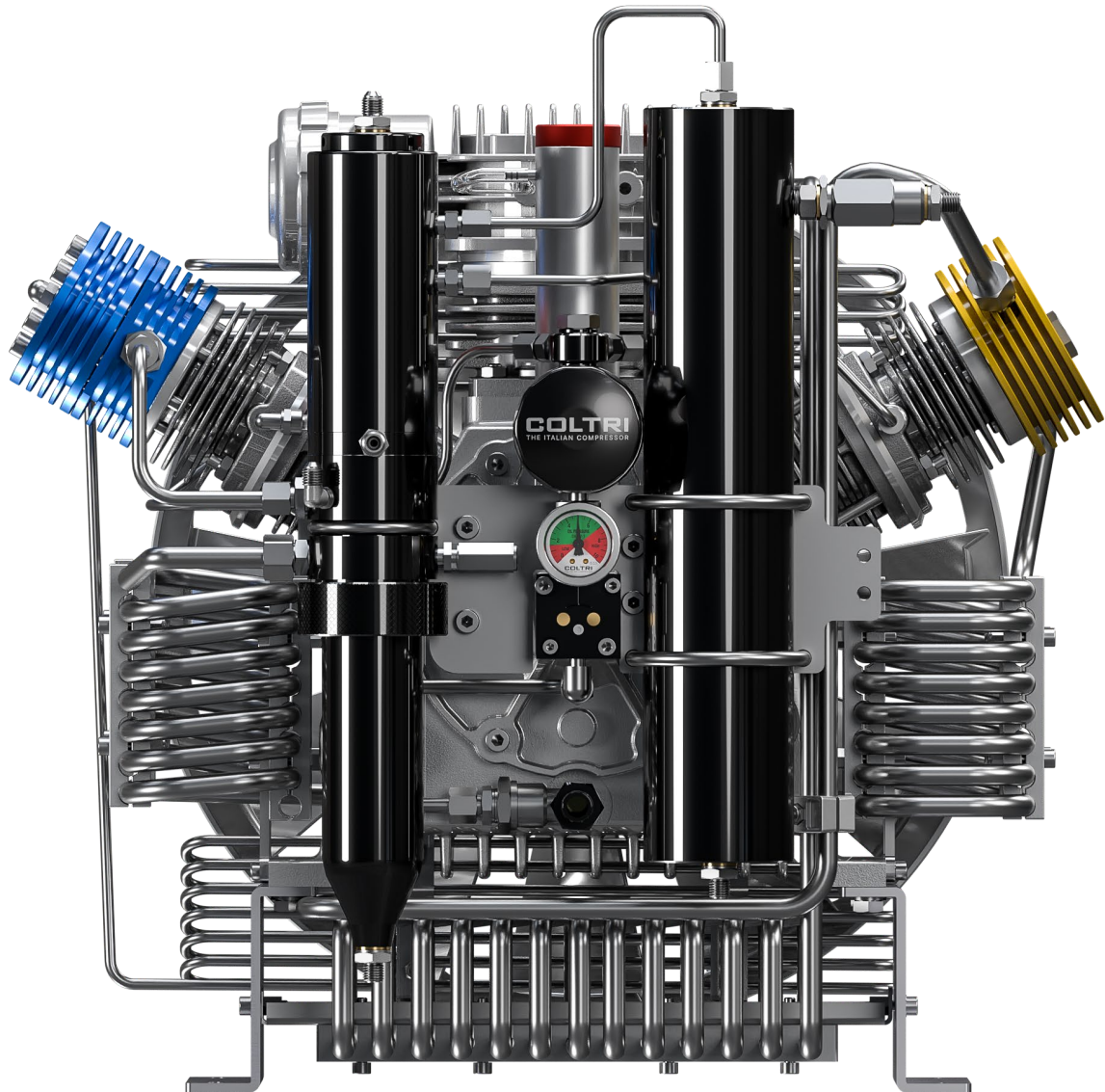

1. Forced lubrication with low pressure gear pump



2. Micron suction filter: 10 μ

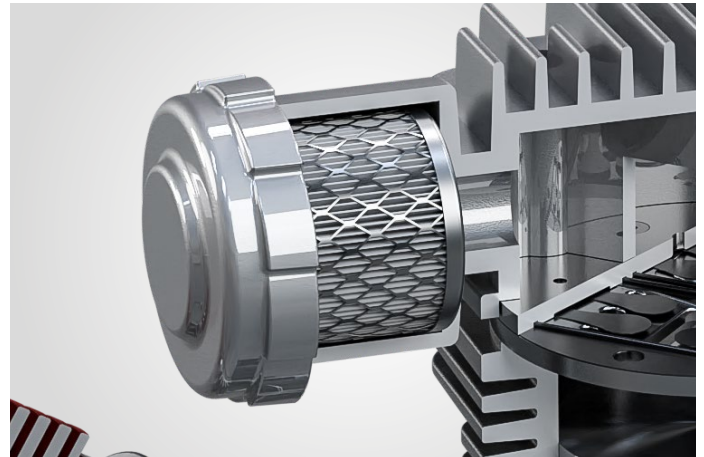

3. Pipes, fittings and nuts in stainless steel AISI 316



4. Synthetic oil with special formulation for HP compressors



5. Intermediate condensate separator after the second stage

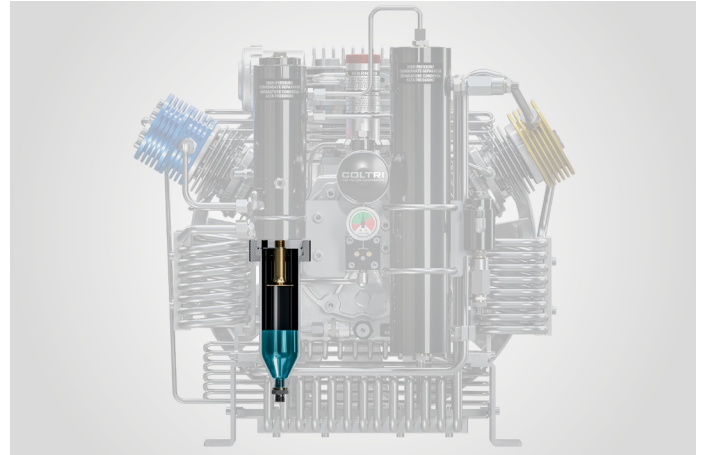

6. High pressure final condensate separator

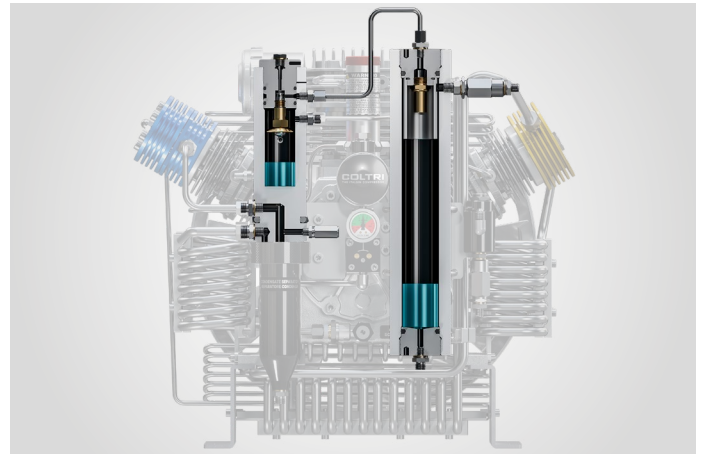

7. Safety valves after each stage of compression

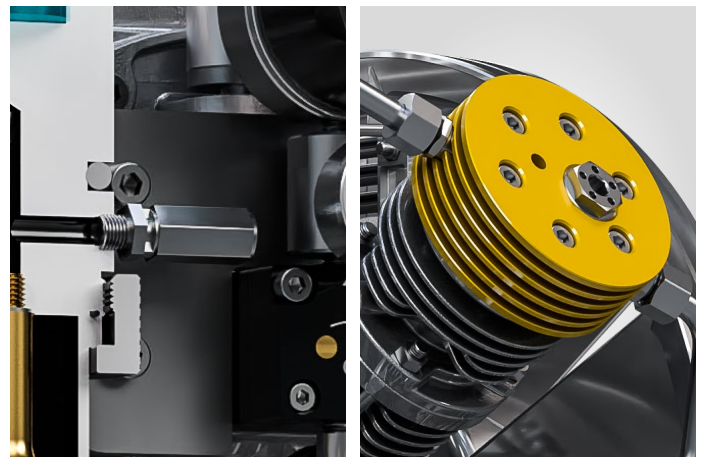

8.
Die-cast aluminum
cylinders with barrel
coating in nicasil



9.
Forged aluminum
connecting rods



10.
Crankshaft
forged steel

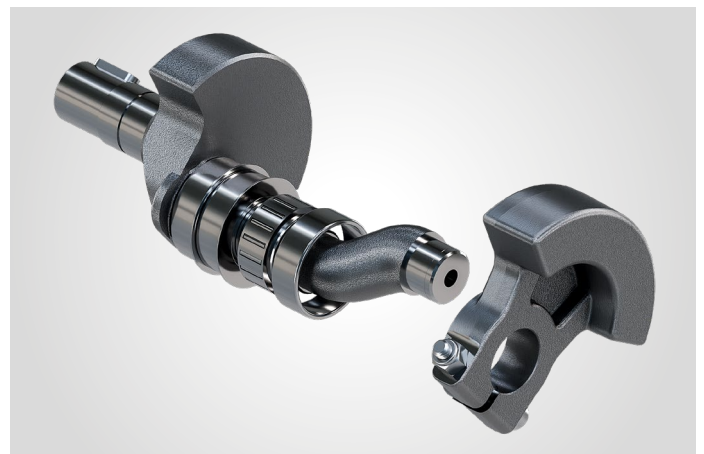

11.
Stainless steel second
and third stage valves

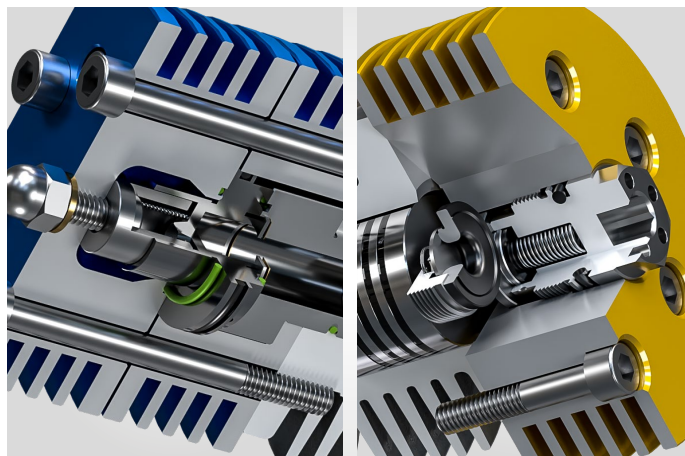

12.
Roller Bearings
for intensive work



13.
Third stage in tempered
steel with 5 segments
in special cast iron

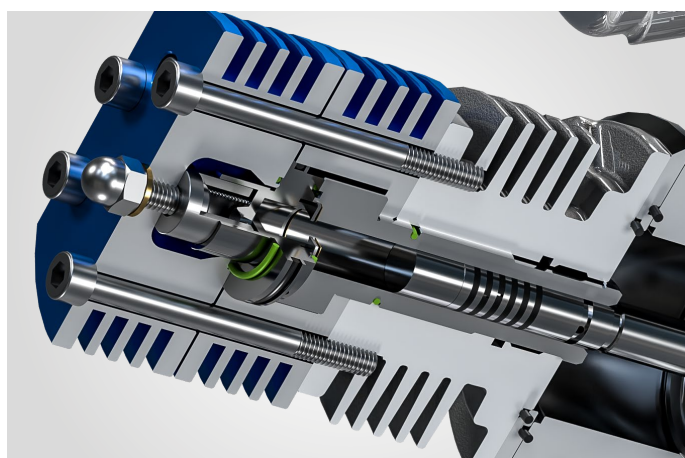

14.
Second and third stage
with pushing pistons
to eliminate lateral forces
on the pistons

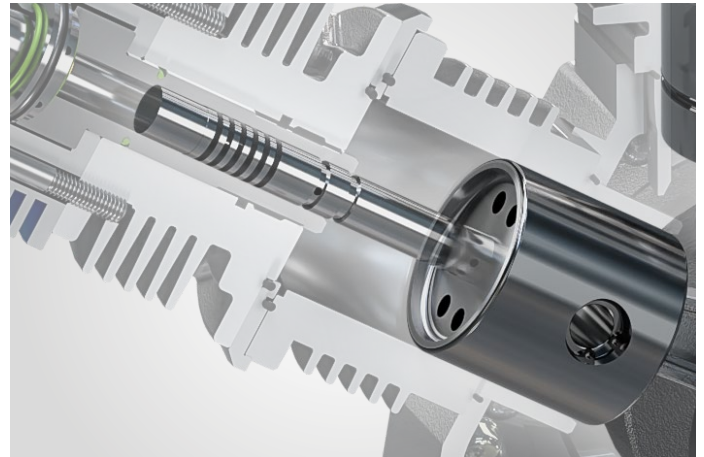

15.
Label
CE certification

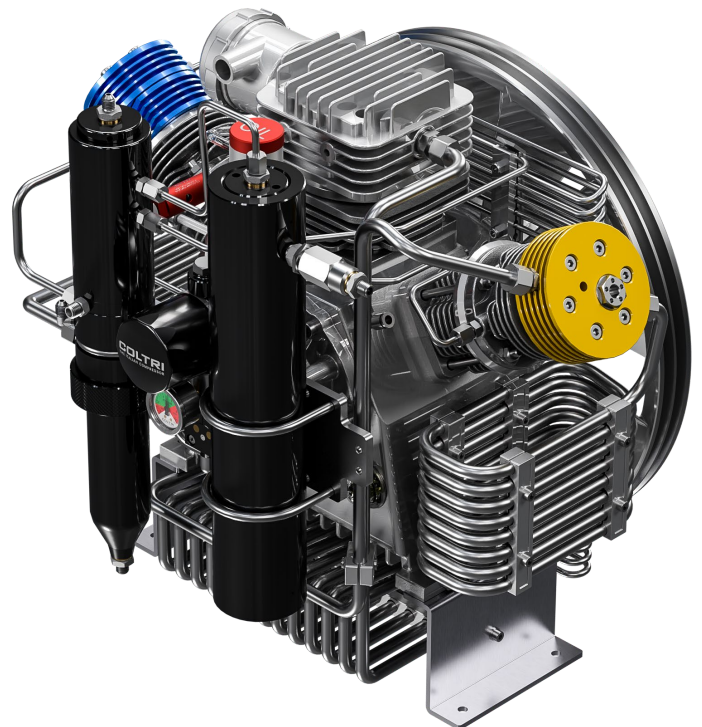
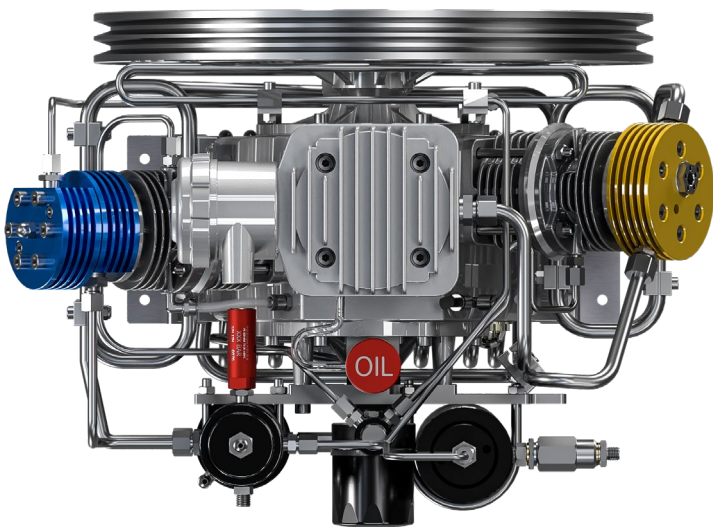
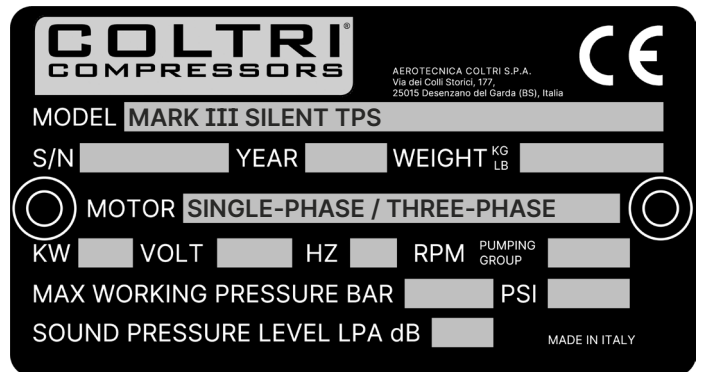

Compressor block

	GP 315 TPS (ex MCH 16 TPS)			GP 380 TPS (ex MCH 23 TPS)	
	210 EM	235 ET	315 ET	345 ET	380 ET
Charging rate Measured during 10 liters cylinder filling from 0-200 bar tolerance +/- 5% at + 20 ° C ambient temperature.	210 l/min	235 l/min	315 l/min	345 l/min	380 l/min
Speed RPM	1.040	1.240	1.600	1.240	1.400
Number of stages	3				
Number of cylinders	3				
Cylinder bore 1st stage	95 mm				
Cylinder bore 2nd stage	38 mm				
Cylinder bore 3rd stage	14 mm			15 mm	
Stroke	40 mm			50 mm	
Direction of rotation (from flywheel side)	Left - counter clockwise				
Drive type	V-belt A type				
Intermediate pressure 1st stage	~ 6 bar				
Intermediate pressure 2nd stage	~ 45 bar				
Amount of oil	1,8 liters				
Intake pressure	1,3 bar _a – 300 millibar				

Standard equipment

Purification system HYPERFILTER

DOUBLE HYPERFILTER regenerable or disposable cartridge



- ① HYPERFILTER body
- ② Upper cap
- ③ O-Ring
- ④ Cartridge spring
- ⑤ HYPERFILTER cartridge
- ⑥ Fitting
- ⑦ Lower cap
- ⑧ Stainless hook
- ⑨ Upper cap
- ⑩ Felt disc
- ⑪ Network Disc

Purification system

Operating pressure (Standard)

Hyperfilter x 2

250 bar / 330 bar / 360 bar

Operating pressure max. (PS)

420 bar

Processable air capacity
(air inlet temperature in the filter 20° C at 300 bar)¹



3.050 m³

¹ When using a filter cartridge without HOPCALITE CO CATALYST.

When using a cartridge with CO-removal, the processable air capacity is reduced by ca. 20%.

Separator system

- Interstage separator after 2nd stage, forged and anodized aluminum.
- Double final separator for removal of oil/water condensate
- Final safety valve, mounted on the separator housing
- Pressure maintenance valve / non-return valve

	Direttiva PED 2014/68/UE - Modulo D PED Directive 2014/68/EU - Module D		
	Conformità al tipo basata sulla garanzia della qualità del processo di produzione Conformity to type based on quality assurance of the production process		
Certificato n. Certificato no.	714-P-1759	REV. 00	
Attrezzatura a pressione Pressure equipment	VALVOLA DI SICUREZZA A MOLLA	Categoria IV	
Tipo	6-05-015		
Fabbricante Manufacturer	Aerotecnica Coltri S.p.A.		
Sito produttivo Production site	Via dei Colli Storti 177 - 25015 Desenzano del Garda BS		
Verbale di verifica Evaluation report	P4300439-01-R04	Numero di pratica Job Number	P4300439

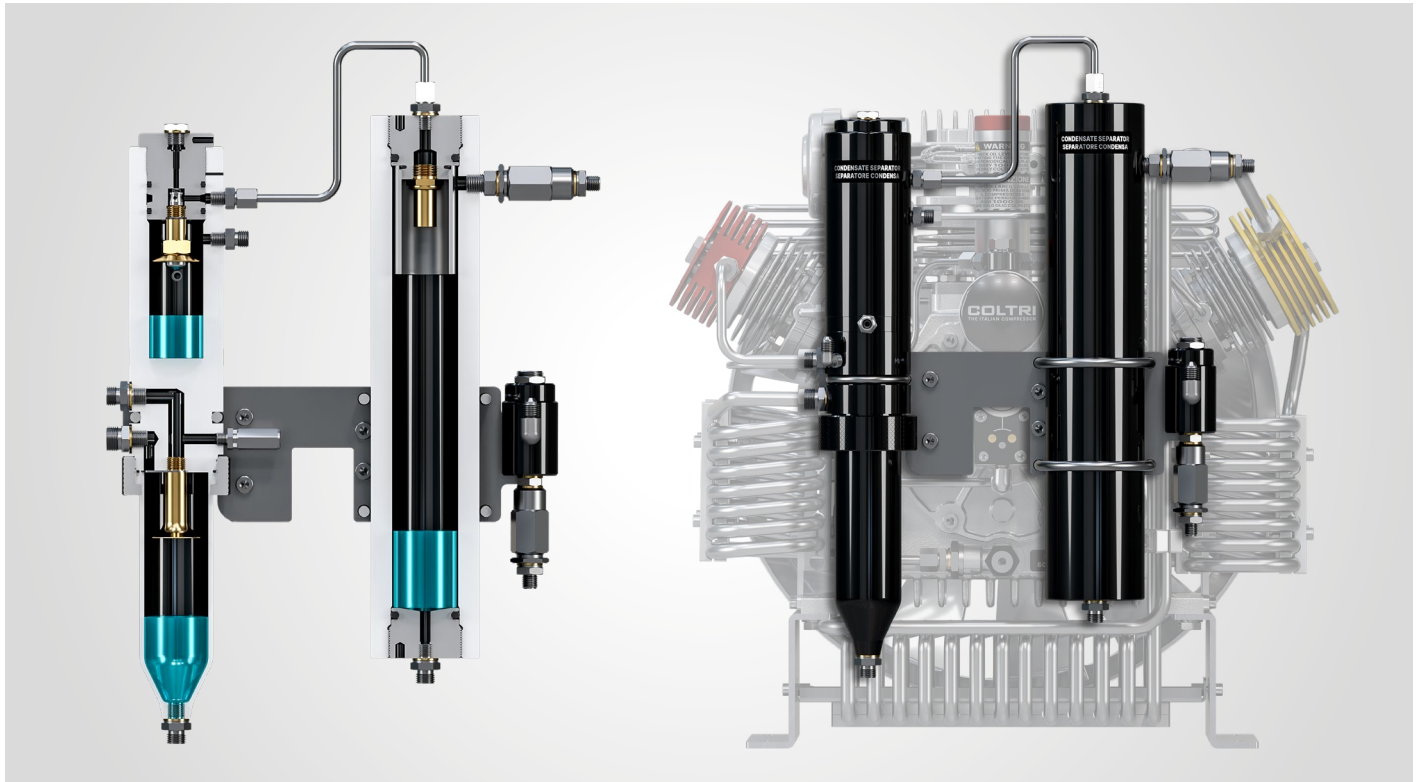

Contamination	Maximum content as per DIN EN 12021:2014	Air quality*
H ₂ O	25 mg/m ³	≤ 10 mg/m ³
CO	5 ppm(v)	≤ 4
CO ₂	500 ppm(v)	≤ 500
Oil	0,5 mg/m ³	≤ 0,5 mg/m ³

* Measured at our facility using ASCO HORA 160 ANALYZER.

1 Only with special filter cartridge with HOPCALITE CO CATALYST. and up to a maximum concentration of 25 ppm CO in intake air.

The compressed clean breathing air then contains a maximum of 5 ppm CO.

2 The level of CO₂ in the intake air must not exceed the maximum level of CO₂ as per EN 12021:2014

3 Reported values exceed ISO 8573-1 standards.

Filling connections

2 Filling connection to choose from: DRV DIN 232 bar and DRV DIN 300 bar.



Filling connection DRV DIN 232 bar
COD. DRV232

Filling connection DRV DIN 300 bar
COD. DRV300

Filling device	DRV DIN 232	DRV DIN 300
Nominal pressure (PN)	250 bar	330 bar
Valve design	Filling valve with integrated ventilation, with cylinder connector G 5/8" according to EN 144-2 and 477 PN232	Filling valve with integrated ventilation, with cylinder connector G 5/8" according to EN 144-2 and 477 PN232

Filling hose

1200 mm stainless steel fittings - max working pressure 420 bar



Electronic pressure switch

The instrument allows to visualize the pressure expressed in bar, psi or MPa.

Through the programming buttons it allows to set the intervention pressure of the relay contact (SPDT) and hysteresis. The settings are protected by passwords at 3 levels: manufacturer, customer and end user. The instrument also has the function of hours counter and no. of cycles of separator intervention, ensuring a general improvement of the operation of the recharge station over time and the longevity of its filters.



According to EN 10204 Type 2.1

N.	Caratteristiche / Characteristics	Valori richiesti / requested values	Tolleranze / Tolerances	Strumento di controllo / Test equipment	Esito verifiche / Test Result
1	Setpoint alarm	300 bar	err.max 1,5% vfs	Elect. load 16V/10mA max	OK
2	Setpoint hysteresis	10 bar	err.max 1,5% vfs	Elect. load 16V/10mA max	OK
3	Range	0 - 400 bar	err.max 1,5% vfs	Pressure gauge cl. 0,25% vfs	OK
4	Process connection	G1/4"	Tab ISO228	Ring ISO228	OK

Compressor control and automatic condensate drain system

- ON/OFF switch with motor protection switch.
- Optional: autostart at 60 bar hysteresis.
- Transformer.
- Pressure switch stops compressor at final pressure.
- Drainage of all separators between the individual stages and also of the final separator during compressor operation (standard drain interval every 15 minutes for a period of 6 seconds).
- Timer for automatic condensate drainage device.
- Integrated vacuum start-up (automatic drain when the unit is switched off).
- Condensate collection tank 5 liters, with silencer; capacity approx. 3 liters, for environmentally friendly disposal of condensate.
- Interstage pressure gauges display the operating pressure for the individual compression stages. This pressure information allows you to check the tightness of the valves (inlet and outlet) of each stage and quickly identify potential sources of failure.

The interstage pressure gauges are mounted in the compressor frame.

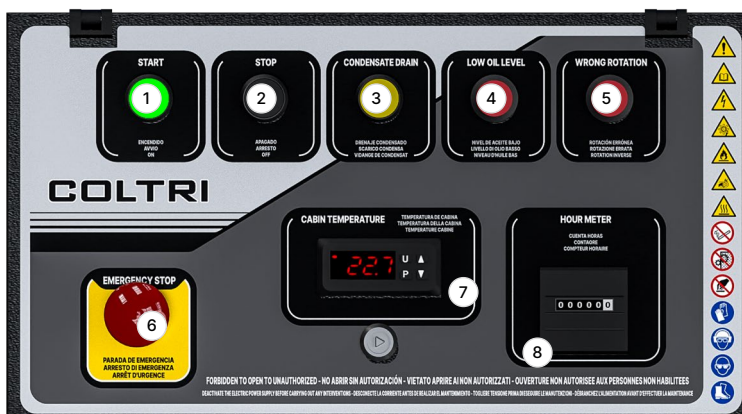

- 1 Power button
- 2 Stop button
- 3 Condensate drain button
- 4 Oil level warning light
- 5 Wrong direction indicator light
- 6 Emergency button
- 7 Inside temperature cabin/cooled air
- 8 Operating hour meter

Interstage pressure gauges

The function of the interstage pressure gauges is to show the operating pressure of the individual compression levels. This information is indispensable because it allows to quickly recognize a possible error by checking the tightness of the respective level valves (inlet and outlet). The interstage pressure gauges are mounted on the control panel of the compressor.

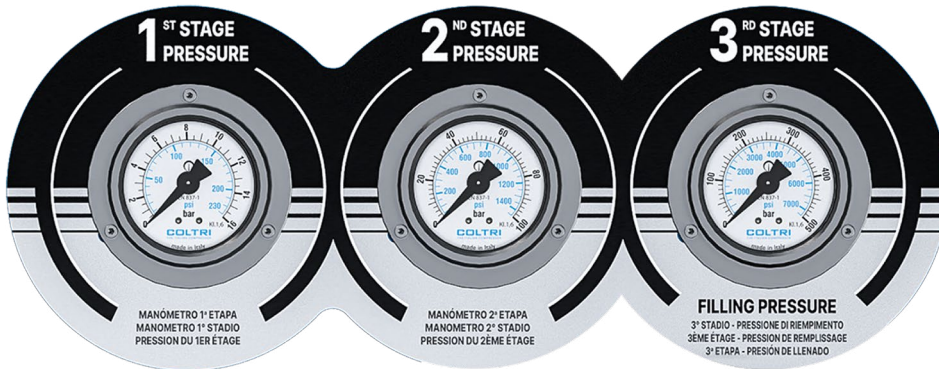

Soundproof frame

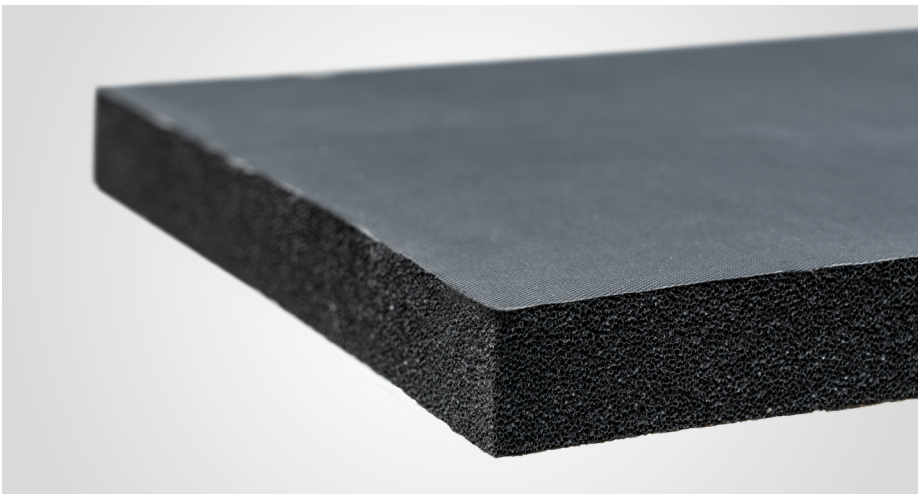

Polyether-based expanded polyurethane impregnated with halogen and CFC-free flame retardant substances. Soundproofing useful in any environment that requires a strong reduction of high frequencies.





Certifications

Color	Black	
Thermal conductivity	W/mk 0,040 40° C	
Temperature resistance	-70° C - 100° C	
Density	75 / 110 Kg/m ³	ISO 1855
Hardness	> 300 N	ISO 2439 (ILD% 40)
Tensile hardness	> 85 Kpa	ISO 1798
Resistance to de-tensioning	> 85 %	ISO 1798
Self-extinguishing	Class 0 / Class 1	BS 476 Part 6 / BS 476 Part 7

Data sheet single-phase electric motor 4 kW

		SPECIFICA TECNICA MOTORE EL. <i>Electric motor technical data sheet</i>		Potenza/ Power (kW)	Poli/ Poles
				4	2
		Data		25/06/2015	Rev. 0
No	Descrizione/Description	Dati/Data			U.d.m.
1	Codice Soga / ref.code	125413			
2	Modello / Motor type	MM1 100L C/2			
3	Descrizione / Description	Single-phase motor with starting capacitor 4kW 2 Poles 220V 50Hz			
4	Carcassa motore / Framesize	100L			
5	Poli / Poles	2			
6	Forma di costruzione / Mounting type	IM B3			
7	Potenza nominale / Rated output	4			[kW]
8	Fattore di servizio / Service factor	1.0			
9	Tipo di servizio / Duty type	S1			
10	Tensione / Rated voltage	220			[V]
11	Frequenza / Rated frequency	50			[Hz]
12	Corrente nominale / Rated current	25,2			[A]
13	Velocità nominale / Rated speed	2850			[min ⁻¹]
14	Fattore di potenza / Power factor	0,92			
15	Coppia nominale motore / Rated motor torque	13,4			[Nm]
17	Corrente avviamento / Corrente nominale Starting current / Rated current	3,9			Isp/In
18	Coppia avviamento / Coppia nominale Starting torque/Rated torque	1,9			Msp/Mn
19	Classe d'isolamento / Insulation class	F			
20	Grado di protezione / Enclosure	IP54			
21	Posizione scatola morsettiera (motore con piedini) Terminal box position (motor with feet)	 A			
22	Terminali potenza / Power leads terminal	CAVO/ CABLE			
23	Peso / Weight	18			[kg]
24	Cuscinetti /bearings	Drive end	6206		
		Non drive end	6203		
Note/remarks: Motore con condensatore permanente 80µF e disgiuntore elettromeccanico e condensatore di spunto 160µF. Motor with 80µF permanent capacitor and centrifugal switch plus 160µF starting capacitor. Targa con logo Coltri Compressors.					

Data sheet three-phase electric motor 4 kW

		SPECIFICA TECNICA MOTORE EL. <i>Electric motor technical data sheet</i>		Potenza/ Power (kW)	Poli/ Poles
				4	2
		Data		07/09/2015	Rev. 1
No	Descrizione/Description	Dati/Data			U.d.m.
1	Codice Soga / ref.code	124341			
2	Modello / Motor type	MT1 100LB/2			
3	Descrizione / Description	Three-phase asynchronous motor 4kW 2 Poles 230/400V 50Hz			
4	Carcassa motore / Framesize	100L			
5	Poli / Poles	2			
6	Forma di costruzione / Mounting type	IM B3			
7	Potenza nominale / Rated output	4	4	4,8	[kW]
8	Fattore di servizio / Service factor	1.0			
9	Tipo di servizio / Duty type	S3-75%			
10	Tensione / Rated voltage	230/400	230/400	440-480 Y	[V]
11	Frequenza / Rated frequency	50	60	60	[Hz]
12	Corrente nominale / Rated current	16,8/9,7	18,8/9,7	9,7	[A]
13	Velocità nominale / Rated speed	2840	3410	3410	[min ⁻¹]
14	Fattore di potenza / Power factor	0,85	0,85	0,85	
15	Coppia nominale motore / Rated motor torque	13,5	11,2	13,4	[Nm]
17	Corrente avviamento / Corrente nominale Starting current / Rated current	5,5			Isp/In
18	Coppia avviamento / Coppia nominale Starting torque/Rated torque	2,8			Msp/Mn
19	Classe d'isolamento / Insulation class	F			
20	Grado di protezione / Enclosure	IP54			
21	Posizione scatola morsettiera (motore con piedini) Terminal box position (motor with feet)	 A			
22	Terminali potenza / Power leads terminal	M5			
23	Peso / Weight	22			[kg]
24	Cuscinetti /bearings	Drive end	6206		
		Non drive end	6206		
Note/remarks: Targa con logo Coltri Compressors.					

Data sheet three-phase electric motor 5.5 kW

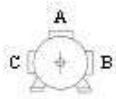
		SPECIFICA TECNICA MOTORE EL. <i>Electric motor technical data sheet</i>			Potenza/ Power (kW)	Poli/ Poles
					5,5	2
		Data	Rev.		0	
24/06/2015						
No	Descrizione/Description	Dati/Data			U.d.m.	
1	Codice Soga / ref.code	124421				
2	Modello / Motor type	MT1 112MB/2				
3	Descrizione / Description	Three-phase asynchronous motor 5,5kW 2 Poles 400/690V 50Hz				
4	Carcassa motore / Framesize	112M				
5	Poli / Poles	2				
6	Forma di costruzione / Mounting type	IM B3				
7	Potenza nominale / Rated output	5,5	5,5	6,5	[kW]	
8	Fattore di servizio / Service factor	1.0				
9	Tipo di servizio / Duty type	S3-75%				
10	Tensione / Rated voltage	400/690	400/690	Δ 440-480	[V]	
11	Frequenza / Rated frequency	50	60	60	[Hz]	
12	Corrente nominale / Rated current	12,6/7,3	12,6/7,3	12,6	[A]	
13	Velocità nominale / Rated speed	2850	3420	3420	[min ⁻¹]	
14	Fattore di potenza / Power factor	0,86	0,86	0,86		
15	Coppia nominale motore/ Rated motor torque	18,4	15,4	18,2	[Nm]	
17	Corrente avviamento / Corrente nominale <i>Starting current / Rated current</i>	7,6			Isp/In	
18	Coppia avviamento / Coppia nominale <i>Starting torque/Rated torque</i>	3,1			Msp/Mn	
19	Classe d'isolamento / Insulation class	F				
20	Grado di protezione / Enclosure	IP55				
21	Posizione scatola morsettiera (motore con piedini) <i>Terminal box position (motor with feet)</i>				A	
22	Terminali potenza / Power leads terminal	M5				
23	Peso / Weight	28			[kg]	
24	Cuscinetti /bearings	Drive end	6206			
		Non drive end	6206			
Note/remarks: Targa con logo Soga.						

Data sheet three-phase electric motor 7.5 kW

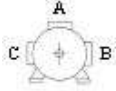
		SPECIFICA TECNICA MOTORE EL. <i>Electric motor technical data sheet</i>			Potenza/ Power (kW)	Poli/ Poles
					7,5	2
		Data	Rev.			
		25/06/2015	0			
No	Descrizione/Description	Dati/Data			U.d.m.	
1	Codice Soga / ref.code	150777				
2	Modello / Motor type	MT1 112MC/2				
3	Descrizione / Description	Three-phase asynchronous motor 7,5kW 2 Poles 400/690V 50Hz				
4	Carcassa motore / Framesize	112M				
5	Poli / Poles	2				
6	Forma di costruzione / Mounting type	IM B3				
7	Potenza nominale / Rated output	7,5	7,5	9	[kW]	
8	Fattore di servizio / Service factor	1.0				
9	Tipo di servizio / Duty type	S3-75%				
10	Tensione / Rated voltage	400/690	400/690	Δ440-480	[V]	
11	Frequenza / Rated frequency	50	60	60	[Hz]	
12	Corrente nominale / Rated current	16,8/9,7	16,8/9,7	16,8	[A]	
13	Velocità nominale / Rated speed	2850	3420	3420	[min ⁻¹]	
14	Fattore di potenza / Power factor	0,86	0,86	0,86		
15	Coppia nominale motore/ Rated motor torque	25,1	21	25,1	[Nm]	
17	Corrente avviamento / Corrente nominale <i>Starting current / Rated current</i>	8,0			Isp/In	
18	Coppia avviamento / Coppia nominale <i>Starting torque/Rated torque</i>	4,0			Msp/Mn	
19	Classe d'isolamento / Insulation class	F				
20	Grado di protezione / Enclosure	IP54				
21	Posizione scatola morsettiera (motore con piedini) <i>Terminal box position</i> (motor with feet)				A	
22	Terminali potenza / Power leads terminal	M5				
23	Peso / Weight	33			[kg]	
24	Cuscinetti /bearings	Drive end	6206			
		Non drive end	6206			
Note/remarks: Targa con logo Coltri Compressors.						

Presec. Filter control system

Includes:

Filter cap with sensor + control unit + cartridge.

To be installed with the Hyperfilter filter system filter system on the compressor.

If you choose the Presec system, you cannot also install the the SAM Multigas Analysis System.

The Presec system is connected through a probe with the first filter cartridge and detects its saturation status transmitting to the indicator the relevant switching signals according to the status. If the filter cartridge is exhausted, the compressor is switched off and cannot be started until the cartridge is replaced.

The presec system displays 4 levels of cartridge saturation through 3 relays connected to 3 leds:

Stable green light (a):

- The system is operational; OK cartridge

Yellow light button (b):

- Pre-alarm; cartridge is running low and must be replaced soon.

Red light button (c):

- Alarm; remove cartridge, replace immediately.

Red light button (c):

- Alarm; filter cartridge is missing or filter system is interrupted; compressor shuts down and cannot be turned back on without inserting a new cartridge or discovering the source of the alarm.

While the yellow light is pulsing (b), the steady green light (a) will still be on because the filter cartridge will not be fully saturated.

If no LED lights up, it means that the PRESEC lacks power or that the electrical system is faulty.

Filter saturation values

Light	Humidity (mg/m3)
Green	15 - 20
Yellow	20 - 25
Red	> 25





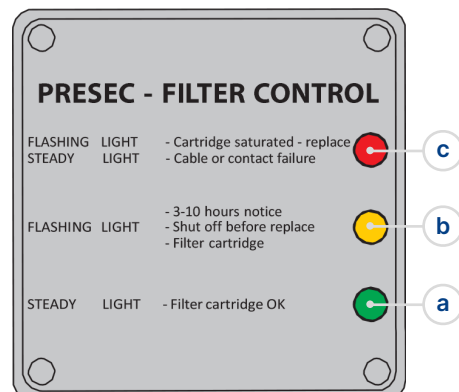





COD. SC000550







C - Monitor

Final filter monitoring system, oil change and technical interface.

The interface consists of an LCD display, a button  and two indicators (, ). The decimal points next to the digits are indicator lights to indicate alarms or warnings in progress. Each dot is associated with an explanatory icon (, , ). The icon  indicates an alarm condition while the symbol  indicates normal operation. Press the button  to scroll through the different functions of the menu. When pressed, the function is displayed the function and after two 2 seconds the related data.



COD. SC001200

- | | | |
|---|--|---|
|  Display |  Service indication |  Operation indicator |
|  Cartridge saturation |  Battery charge level | |

Multi-Gas Analysis System (SAM)

Sensor CO + CO₂ + H₂O (SC000727/A)

Sensor CO + CO₂ + H₂O with VOC (SC000727/B)

The Coltri Multi-Gas Analysis System is a measuring instrument capable of monitoring air quality. Its application includes continuous monitoring of environmental gases, hyperbaric chambers, safety, medical, air quality.

Available sensors:

- Oxygen O₂
- Carbon dioxide CO₂
- Carbon Monoxide CO
- Humidity H₂O
- Gas Temperature
- VOC (Volatile Organic Compound)
- Helium in Air



General specifications

COD. SC000727/A - SC000727/B

Input voltage requirement	10-35 Vdc
Internal Battery	Rechargeable lithium-ion battery. One cell 1400 mAh Li ion 3.7 V
Sensors	Up to 6 sensors
Output	Acoustic alarm
Serial Connection	1 RS232 interface. Transmission speed up to 115000 baud, on request RS485 interface
Measurement resolution	Bipolar 24-bit A/D converter. Drift in automatic temperature compensation.
Conversion rate	10 ms
Sampling time	100 ms (min) for each channel
Signal measurement accuracy	0.1% Full scale +/- 1/2 LSB
Input device	Rotary knob with central push
Color Display	TFT 320 × 240 dot resolution, LED backlighting
Display light intensity	600 nits (cd/m ²)
Memory	Micro SD card writer/reader
Microprocessor	Cortex M4

BUZZER ALARM

There is an audible warning alarm on board.

SERIAL INTERFACE

Standard RS232 interface for connection to PC. It is possible to read measurements remotely and to program the instrument, software is available on request.

NON-VOLATILE MEMORY

SAM features non-volatile memory that retains configuration data and settings for 10 years without power.

Remote charging panels with lever

Single pressure

- 4 Lever taps
- 1 Gauge
- 4 HP hoses 1.20 m - 3.9 ft DIN 232 bar or DIN 300 bar or INT/YOKE
- 1 HP hose 3 m - 9.8 ft from compressor



COD. SC000327/N

Double pressure

- 4 Lever taps
- 2 Gauges
- 1 Pressure regulator
- 2 HP hoses 1.20 m - 3.9 ft DIN 232 bar or INT/YOKE
- 2 HP hoses 1.20 m - 3.9 ft DIN 300 bar
- 1 HP hose 3 m - 9.8 ft from compressor



COD. SC000331/N



Filling connection 232 bar
for lever tap with safety pin
COD. SC000936

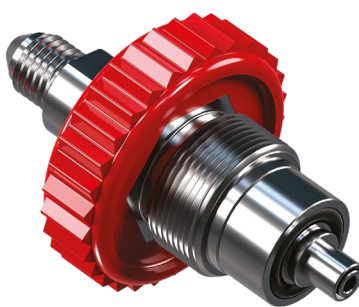

Filling connection 300 bar
for lever tap with safety pin
COD. SC000937



Filling connection INT/YOKE
for lever tap with safety pin
COD. SC000935

Remote charging panels

Single pressure Charging panel

- 4 DRV DIN 232 bar or DRV DIN 300 bar
- 1 Gauge
- 4 HP hoses 1.20 m - 3.9 ft
- 1 HP hose 3 m - 9.8 ft from compressor



COD. SC000325/N

Double pressure Charging panel

- 2 DRV DIN 232 bar
- 2 DRV DIN 300 bar
- 2 Gauges
- 1 Pressure regulator
- 4 HP hoses 1.20 m - 3.9 ft
- 1 HP hose 3 m - 9.8 ft from compressor



COD. SC000329/N



Filling connection DRV DIN 232 bar
COD. DRV232



Filling connection DRV DIN DIN 300 bar
COD. DRV300

Filling connections optional

DRV DIN 232 bar with gauge



COD. DRV232/MANOM

DRV DIN 300 bar with gauge



COD. DRV300/MANOM

Hoses

Width	COD.
1,5 m / 4.9 ft	SC000461-1500-AIR
2,0 m / 6.5 ft	SC000461-2000-AIR
3,0 m / 9.8 ft	SC000461-3000-AIR
4,0 m / 13.1 ft	SC000461-4000-AIR
5,0 m / 16.4 ft	SC000461-5000-AIR
8,0 m / 26.2 ft	SC000461-8000-AIR
10,0 m / 32.8 ft	SC000461-10000-AIR



Aerotecnica Coltri S.p.A.

Via dei Colli Storici, 177
25015 Desenzano del Garda
Brescia - Italy

Ph. +39 030 9910301
+39 030 9910297

info@coltri.com

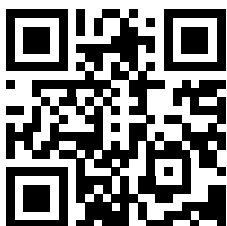

coltri.com



COLTRI
THE ITALIAN COMPRESSOR